

# Roura Material Handling, Inc.

Clinton Twp. MI 48035    Holly Springs, MS 38635  
(800) 968-9070    (800) 654-9147  
www.RouraMH.com

## CASTER INSTALLATION & REPLACEMENT INSTRUCTIONS

Review the entire instruction before assembling the casters onto the hopper. Consult with the factory in the event that there are questions or problems at the time of assembly.

### CASTER OPTION

NOTE: Hoppers ordered with casters include (4) caster pads (welded in place), (2) Swivel casters, and (2) fixed casters.

NOTE: Adding casters will reduce the rolling load capacity of some models. Capacities are:

Semi-Steel-1,200 lb. per wheel; Mold-on-Rubber 600 lb. per wheel; and Poly-on-Steel-1,200 lb. per wheel.

**Assembly must be performed by suitably trained personnel, with access to the appropriate equipment and tools.**

1. Using a Fork-Lift Truck, make sure that the parking brake has been applied, then lift the hopper to a **safe working height**.
2. Once the hopper has been lifted to the desired height, locate the caster pad brackets found in all four corners of the hopper frame.
3. Swivel casters are to be placed in the back of the hopper frame and Fixed casters are to be placed in the front of the hopper frame.
4. Place one end of the caster plate into the slot as shown in Figure 2. Insert the caster plate into the caster pad. Insert the bolt into the caster pad as shown in Figure 3 and screw on the nut making sure it is tight. This will hold the caster into the caster pad. Repeat these steps for all remaining casters.
5. Return to the Fork lift truck and lower the hopper to the floor.

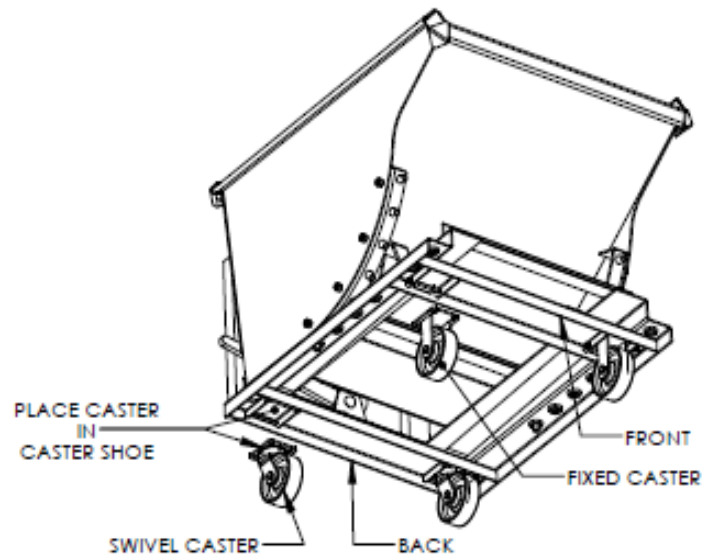

**Figure 1**

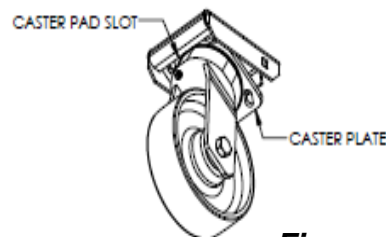

**Figure 2**

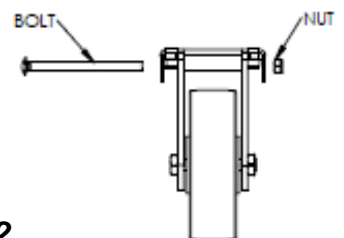

**Figure 3**

### PARTS



FIXED CASTER



SWIVEL CASTER



QUICK CHANGE  
CASTER PAD