



ROURA
MATERIAL HANDLING

Michigan: (800) 968-9070

Mississippi: (800) 654-9147

rouramh.com



RRB-10-270 (RUGGED ROTATOR BOX)

MODEL #	L	W	H	WEIGHT
RRB-10-270	48 1/2"	37"	36 5/8"	312 LBS

The Rugged Rotator Box is designed for the collection and storage of bulk and scrap material. This box can be dumped using a forklift equipped with a rotational fork attachment. The standard model is made of all welded carbon steel with drain plug, 4-way fork entry and plastic lid.

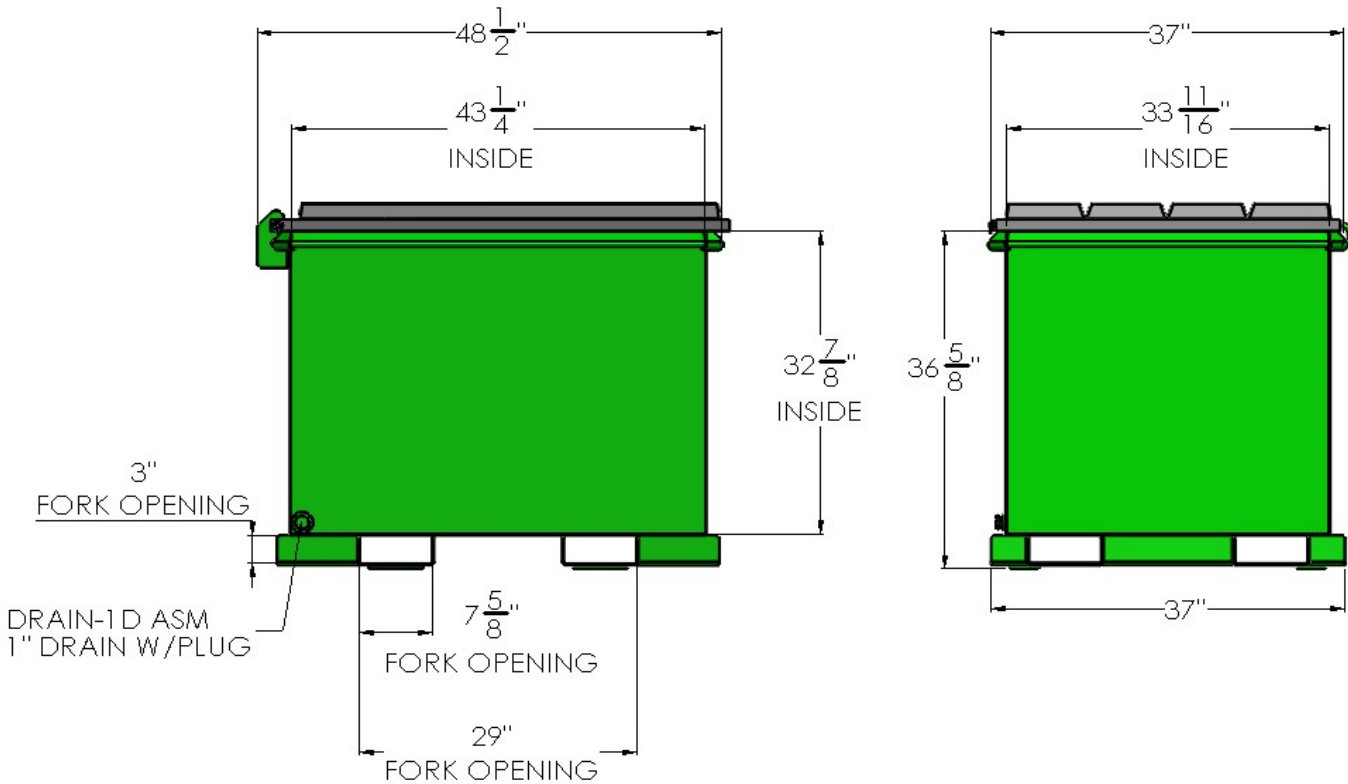
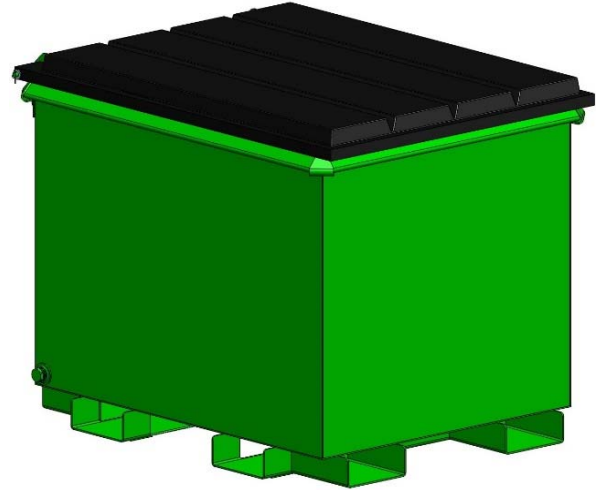

- 10 GAUGE STEEL BOTTOM, 10 GAUGE STEEL FORMED SIDES. FORMED BOX TUBE FORK OPENINGS FOR SUPERIOR STRENGTH WITH SKID RESISTANCE PLATES.
- 4000 LBS. MAX LOAD CAPACITY.
- BRIGHT SAFETY GREEN ENAMEL PAINT.
- OPTIONS: CASTERS, CRANE EYES, CUSTOM COLORS.
- CUSTOM SIZES ARE AVAILABLE UPON REQUEST.

"FOR ALL YOUR MATERIAL HANDLING NEEDS!"