

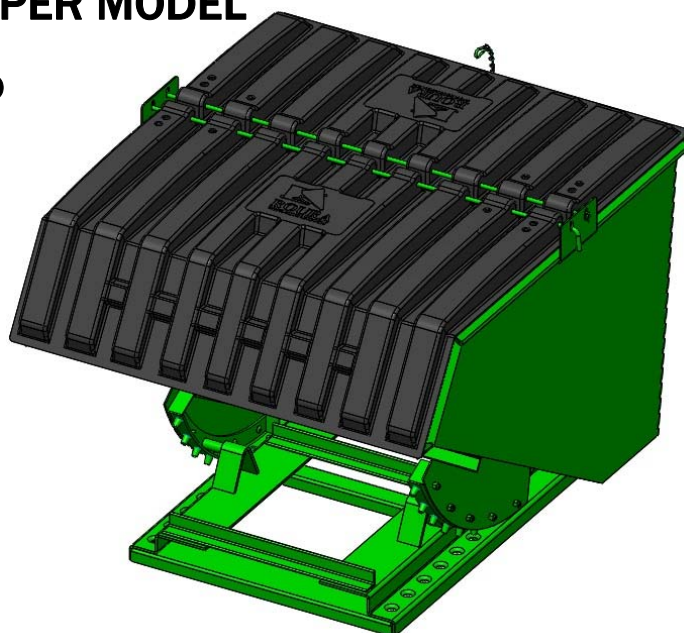

PLASTIC LID HOPPER MODEL

H-PLDA-540 2 CU YD



H-PLDA-540

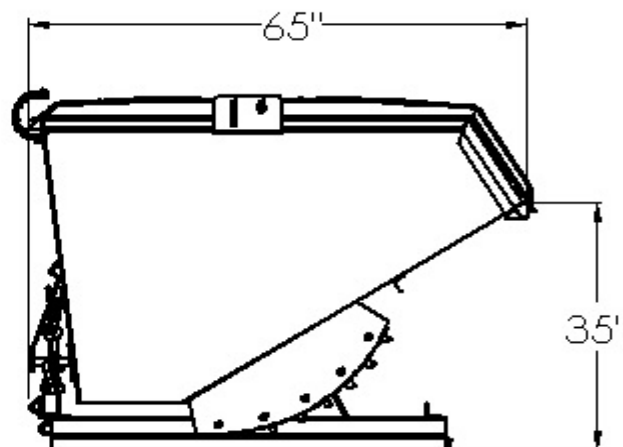
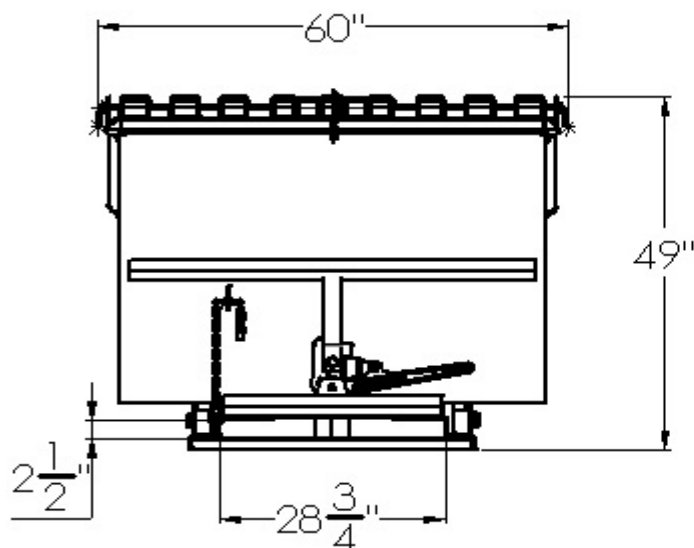

THIS ITEM IS NON-RETURNABLE

MODEL #	SIZE	L	W	H	LH	FORK OPENING	WEIGHT	CAPACITY
H-PLDA-540	2 CU YD	65"	60"	49"	35"	2 1/2" X 28 3/4"	864 LBS	6,000 LBS

STANDARD ITEMS

- DUCTILE IRON HANDLE
- SECURE FLIP LATCH
- MAST SECURE CHAIN
- DURABLE SINGLE WALL POLY LID
- DRIP ANGLE FOR LIQUID COLLECTING
- SECURE LID CHAIN (FOR DUMPING PURPOSE)
- PAINTED ROURA GREEN (OPTIONAL COLORS ARE AVAILABLE)