

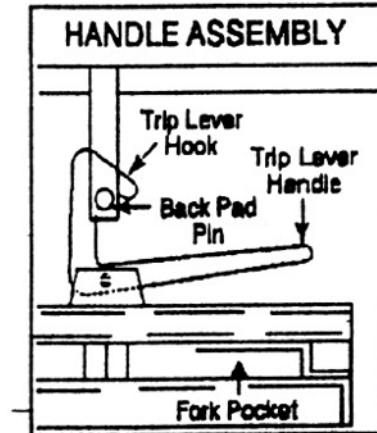

Roura Material Handling, Inc.

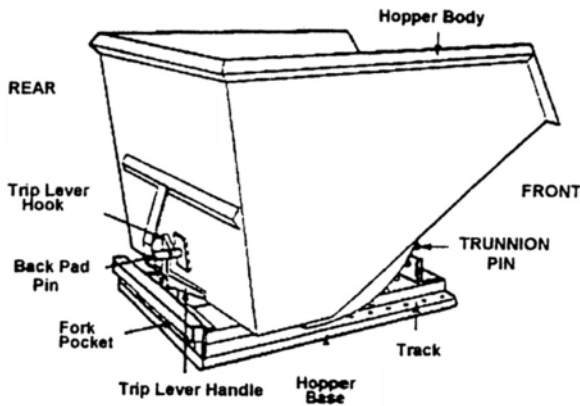

SELF-DUMPING-HOPPER OPERATION & SAFETY SHEET

ALWAYS THINK SAFETY FOR YOURSELF AND OTHERS FIRST.

INSPECT SELF-DUMPING HOPPER AND FORKLIFT TOGETHER TO MAKE SURE NEITHER INTERFERES WITH THE FUNCTIONING AND SAFE OPERATION OF THE OTHER. FOLLOW ALL SAFETY WARNING AND MANUFACTURER'S INSTRUCTIONS FOR THE USE OF THE FORKLIFT.

ONLY PROPERLY TRAINED PERSONNEL MAY USE OR OPERATE SELF-DUMPING HOPPERS WITH OR WITHOUT THE AID OF FORKLIFTS.

UNDERSTAND AND FOLLOW ALL WARNING AND INSTRUCTIONS ATTACHED TO THE HOPPER AND IN THIS MANUAL. CONTACT ROURA FOR REPLACEMENT DECALS.

FOLLOW ALL OF YOUR COMPANY SAFETY RULES.

NEVER USE A DAMAGED SELF-DUMPING HOPPER. ALWAYS INSPECT AND REPAIR PRIOR TO USE. (SEE SECTION V.)

I. HANDLING A SELF-DUMPING HOPPER:

- A. To prevent accidental dumping, the trip lever hook must fully engage the backpad pin. Dumping causes the hopper to rock forward and discharge its contents creating a potential crushing hazard.
- B. Never overload the hopper. Overloading may cause the hopper to fail.
- C. Do not fill the hopper so the contents are overflowing. Material may fall out causing an impact hazard.
- D. Self-dumping hoppers are designed to be handled by forklifts as conventional loads. To prevent the hopper or forklift from becoming unstable, take the following precautions:
 1. Place the forks within the fork pockets using the widest possible spacing.
 2. Insert the forks into the base as far as possible without protruding out the front of the base.
 3. Restrict the loaded weight of the self-dumping hopper below the forklift capacity.
 4. Caution: The forklift's capacity might be exceeded if the self-dumping hopper's center of gravity is beyond the forklift's load center (as stated on the forklift's load plate) even though the weight of the filled hopper is less than the forklift's rated load capacity.
 5. Know the characteristics and weight of the material in the hopper to be dumped. The center of gravity will shift forward when the hopper rocks to the full dump position.
 6. The weight capacity rating of the self-dumping hopper is not to be confused with and in no way implies the proper forklift weight capacity rating.
- E. When stacking self-dumping hoppers, take the following precautions to avoid collapse or crushing:
 1. Stack only hoppers that are equipped with the stacking feature.
 2. Stack empty hoppers only.
 3. Do not stack over (3) high.
- F. Keep the area in front of the hopper free of personnel to avoid injury if the hopper base is pushed forward, if the forks protrude through the base, if the hopper is accidentally dumped or if the contents spill.
- G. Personnel must never place any part of their bodies beneath an elevated hopper. The forks lifting the hopper may fall suddenly or may be lowered accidentally.
- H. Using optional equipment:
 1. 40-MSC Chain (CHAIN-40-MSC) after the forks have fully entered the base, neutralize the forklift controls, wrap the chain around the forklift carriage and hook the grab hook at the end of the chain to the chain. This will prevent the hopper from sliding off the forks if

the base slides forward.

2. Flip Over Handle Latch (HAN-CAST-FOHL) is engaged by flipping the device to the left. This prevents the trip lever handle from being released. The flip over handle latch may be engaged before filling the hopper and should be disengaged by hand after transporting, but before fully elevating for dumping. Before dismounting forklift to disengage flip over handle latch, stop, position forks to the appropriate work level, place the forklift in neutral and set the parking brake.

3. Barrel Bolt Latch (SBL-ASM) Slide bolt into locked position so that base and body are locked together. The barrel bolt latch may be engaged before filling the hopper and should be disengaged by hand after transporting, but before fully elevating for dumping. Before dismounting forklift to disengage the barrel bolt latch, stop, position the forks to the appropriate work level, place the forklift in neutral and set the parking brake.

II. TRANSPORTING SELF-DUMPING HOPPERS

A. Transport the latched self-dumping hopper as a conventional forklift load.

B. Lift the hopper 2" to 4" off the surface, tilt the mast back fully and move the hopper at a slow speed to minimize forklift rollover, accidents and to keep the hopper from sliding off the forks due to sudden stops. Keep the hopper as low as possible.

C. Drive the forklift in reverse if the hopper obscures visibility.

D. Never allow any one to ride on any part of the self-dumping hopper or forks.

E. Keep all personnel away from the hopper during transport. There is an increased danger from objects falling from the elevated hopper.

III. ELEVATED DUMPING OF SELF-DUMPING HOPPERS:

A. Raise the hopper on the forklift's forks and position it so the hopper base is resting on the edge of the container into which the hopper is to be dumped. The front of the hopper base should overhang the container by at least 6 inches. The hopper should be placed so that the body does not strike anything while rocking forward. This may cause the hopper body to jump out of the tracks and off the base. Before dismounting the forklift, stop, place the forklift in neutral and set the parking brake.

B. Avoid dumping with the forklift on an incline.

C. Self-dumping hoppers are designed to dump automatically upon release of the trip lever when the hopper is nearly full with uniform weight throughout the hopper.

D. Raising the trip lever begins the dump cycle by unlatching the trip lever hook from the back pad pin. Elevated hoppers that are too high to be released by hand should be unlatched by pushing upward on the trip lever handle using a properly designed rod or a pole.

1. All personnel must stand clear before releasing the trip lever.

2. To avoid falling objects during the dump phase, hopper operator should be positioned to the side and rear of the hopper.

3. To release the trip lever more easily, tilt the forklift mast back slightly; this will take most of the load off the back pad pin.

4. Dumping action may be assisted by pushing upward on the rear portions of the hopper body with a pole.

5. After the hopper body rolls forward, if discharged material is piling up and interfering with complete dumping, the forks may be elevated slowly to aid in discharging material from the hopper.

E. **Never release the trip lever by climbing on any part of the forklift or reaching through or around the mast from the forklift operator's position. Climbing or reaching produces fall hazards and creates mechanical hazards caused by accidental activation of forklift controls.**

F. Do not modify the trip lever handle so it can be activated by a rope or chain. Rope tension introduced by tripping, ensnaring or raising the forks can cause inadvertent dumping. Raising the forks or dumping the hopper will pull the rope and any tethered operator upward and forward. Pull down trip lever modifications by the end user are not recommended since they can be accidentally released by being stepped on or by an object falling or being set down on the handle causing inadvertent dumping of the hopper. Roura manufactures specific options for elevated dumping heights that help reduce the risk of injuries.

G. During dumping, never touch any part of the self-dumping hopper except the trip lever handle. Pinch points occur along the tracks, between the hopper base and the forklift truck forks and between the moving hopper and external structures including the mast, backrest and other parts of the forklift truck as well as surrounding objects.

H. Normally, the hopper body will rock back towards the upright position after the contents are discharged.

1. Righting the hopper and latching the trip lever handle may be aided by tilting the forklift mast rearward.

2. When elevated, the hopper may be righted manually using a pole. All body parts must remain clear of the tracks, back pad pin, trip lever handle and rear of the hopper and forklift carriage, mast or forks to avoid crushing hazards.

3. After the hopper is in the upright position, make sure the trip lever hook has latched the back pad pin.

I. To control the hopper dump (dump slowly):

1. The front of the hopper body should be positioned so that the nose is approximately 2" above the side of the container into which the hopper is to be dumped. Make sure the nose is over the side of the container.

2. When the handle is released, the hopper bottom just below the nose will come to rest on the edge of the container.

3. Slowly raise the forks of the lift truck and the hopper body will rock forward slowly and dump its contents.

4. To stop the flow of material or return the hopper to its upright position, lower the forks until the trip lever latches over the back pad pin completely.

IV. GROUND LEVEL DUMPING OF SELF-DUMPING HOPPERS

A. A hopper sitting on the ground may be dumped off the edge of a loading dock or into a recessed area in the ground. Make sure the hopper is positioned so that the front of the

hopper body does not hit the ground when in the full dump position.

1. If the forklift forks have been removed from the fork pockets before dumping, the back of the hopper base must be chained to the ground (or something equivalent) to prevent the rear of the hopper base from lifting up off the ground.
 2. Never stand on the hopper base. During dumping, personnel can be catapulted off the base even when chained.
 3. Even with the base chained, care must be exercised to keep feet clear of base during dumping.
- B. For caster mounted self-dumping hoppers, all movement of the base must be blocked to prevent rolling and pitching during dumping operations. A shifting hopper produces impact hazards.
- C. When setting up a safe zone in front of a self-dumping hopper, account for the tendency for some loads to roll and scatter when dumped.

V. TIPS FOR INSPECTION AND REPAIR OF SELF-DUMPING HOPPERS (Also see the attached Roura parts list with drawings.)

TRIP LEVER HANDLE ASSEMBLY

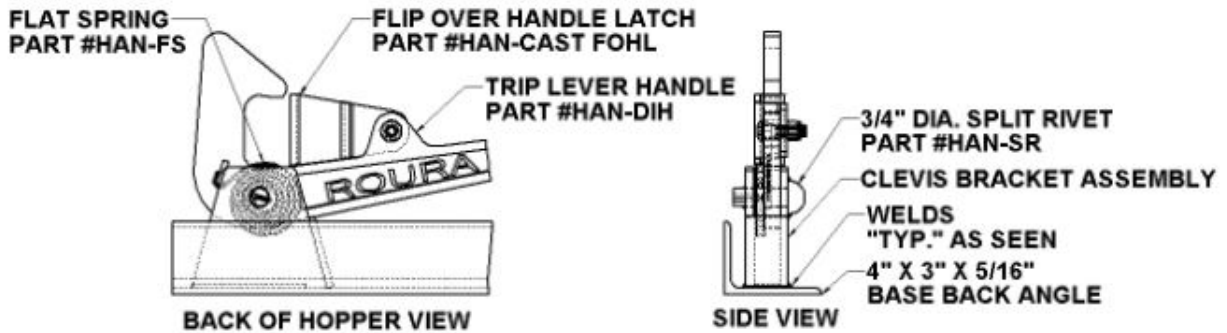

A. Trip lever handle (HAN-DIH, HAN-STH)

<u>OLD PART #</u>	<u>NEW PART #</u>
PT-73-A	HAN-DIH
PT-73-AHD	HAN-STH

1. If broken or cracked, empty the hopper and replace handle.
2. Check for excessive wear on the hook of the trip lever handle. Empty the hopper and latch the handle. Slowly pull up on the trip lever handle. The hopper body should rock back slightly to allow the trip lever handle to disengage from the back pad pin. If the hopper body does not rock back, the underside of the trip lever handle is excessively worn and the handle should be replaced.
3. If the handle is bent, empty the hopper and trip the lever to allow the hopper body to go forward. Bend the handle back to its original position by sliding a piece of pipe over the end of the handle and pulling it away from the hopper body but not past the back base angle. CAUTION: FAILURE TO MAINTAIN THE PROPER HANDLE POSITION CAN CAUSE A PINCH POINT BETWEEN THE HANDLE AND THE BACK OF THE HOPPER BODY.

B. Other trip lever assembly parts

1. FLAT SPRING

<u>OLD PART #</u>	<u>NEW PART #</u>
PT-73-B	HAN-FS

Flat spring (HAN-FS) With the hopper empty, pull up on the handle and then release it. When the handle is released, it should spring back to the closed position. If the handle does not spring back, replace the flat spring.

CAUTION: NEVER TRANSPORT A LOADED HOPPER WITH A BROKEN FLAT SPRING. VIBRATION COULD CAUSE THE TRIP LEVER TO DISENGAGE, ALLOWING THE HOPPER TO DUMP.

2. SPLIT RIVET

<u>OLD PART #</u>	<u>NEW PART #</u>
PT-73-D	HAN-SR

Split rivet (HAN-SR). The split rivet goes through the clevis bracket assembly, the flat spring, the trip lever handle to the opposite side of the clevis bracket assembly. Replace the split rivet if it is bent or broken. Make sure it is welded to the clevis bracket and repair welds if needed.

- a. When replacing the flat spring or the split rivet, always use Roura parts which are in good condition. Do not use other types of springs or fasteners.
- b. Spring tension is achieved by turning the split rivet 1/4 turn clockwise once the outer hook on the spring contacts the boss or rivet on the handle. The split rivet is then

welded to the back and front of the clevis bracket assembly. See Roura's installation instructions for the flat spring and split rivet.

- c. Clevis bracket assembly.(PT-73-CS & PT-73-C) The clevis bracket assembly holds the trip lever handle, flat spring and split rivet together. If the clevis bracket is damaged or bent, it must be repaired or replaced.

C. Back pad pin (BKP-LG-ASM or BKP-SM-ASM) Replace if excessively worn on the top of the pin. CAUTION: EXCESSIVE WEAR ON THE PIN COULD LEAD TO PIN FAILURE ON A LOADED HOPPER.

D. Base cross channels, top angles and Z bar tracks - Repair or replace all bent or broken parts.

CAUTION: FAILURE TO REPAIR OR REPLACE BENT OR BROKEN BASE COMPONENT PARTS COULD CAUSE THE HOPPER TO SLIDE OFF THE LIFT TRUCK FORKS.

- E. **Hopper base track holes** - If the track holes have become enlarged (over 1.5" in diameter) the base assembly should be replaced.

CAUTION: USING A HOPPER WITH ENLARGED TRACK HOLES IN THE BASE ASSEMBLY COULD CAUSE THE HOPPER BODY TO SEPARATE FROM THE BASE.

- F. **Hopper body stops**- Overloading or improper dumping could cause the hopper body stops to become damaged or bent. Damaged or bent stops should be replaced.

CAUTION: DUMPING A HOPPER WITH DAMAGED OR BENT STOPS COULD CAUSE THE HOPPER BODY TO FAIL TO STOP AND CONTINUE ON ITS FORWARD MOTION.

- G. Trunnion pins (PT-61-A) Replace missing trunnion pins.

- H. **Rocker angles and rocker plates**

1. The hopper body should rock forward and back freely. If it does not, the body sides where the rocker angles attach on straight side hoppers or the rocker plates should be bent in or out so that the trunnion pins will enter the base track holes freely.
2. Overloading or improperly dumping a hopper can cause damage where the stops hit the rocker angles. If, in the full dump position, the rocker angles are bent outward where they hit the stops, the rocker angles should be replaced.

CAUTION: FAILURE TO REPLACE DAMAGED ROCKER ANGLES COULD CAUSE THE HOPPER BODY TO SEPARATE FROM THE BASE ASSEMBLY WHEN THE HOPPER IS BEING DUMPED.

- I. Back trunnion pins should line up with the back track holes in the base. The hopper body may jump back on the track if the hopper body hits the container into which the hopper is being dumped. If this has happened, lift the body off the track slightly with a forklift and position the back trunnion pins over the back track holes. Then lower the body down on to the track so the last pin goes in the last hole.

FAILURE TO PROPERLY MAINTAIN AND REPAIR SELF-DUMPING HOPPERS COULD RESULT IN DEATH OR SERIOUS INJURY TO PERSONNEL.

VI. MISCELLANEOUS ACTIVITIES

- A. Do not use lowered hopper as a bulldozer or front end loader. The trunnion pins will be damaged and the track holes will be enlarged. This can cause the hopper body to separate from the base.
- B. Never direct charge furnaces or incinerators. This could result in an explosion due to moisture in the contents of the hopper.
- C. Never perform any maintenance operation on an elevated hopper. This included cleaning, unjamming, inspections and repairs. If trip lever handle will not release, the hopper fails to dump or will not empty completely, lower hopper to ground before investigating.
- D. For safety reasons, consult with Roura's engineering department before making any modifications to a Roura self-dumping hopper.
- E. A self-dumping-hopper is not designed for the use with a forklift truck that has rotating forks installed on the lift truck. The body may come free from the base during the rotational movement of the forks causing potential risk for injury. NEVER USE A SELF-DUMPING HOPPER WITH ROTATING FORKS.

