



ROURA
MATERIAL HANDLING

Michigan: (800) 968-9070

Mississippi: (800) 654-9147

rouoramh.com



3 CU YD DE-WATERING HOPPER 6,000 LBS

MODEL #	L	W	H	WEIGHT
DW-810	70"	63 1/2"	61"	1390 LBS

3 YARD VOLUME CAPACITY

This De-watering hopper is designed for the use in pulp processing, waste treatment plants and any wet application. Roura's De-watering hoppers are available in many sizes for those unique applications.

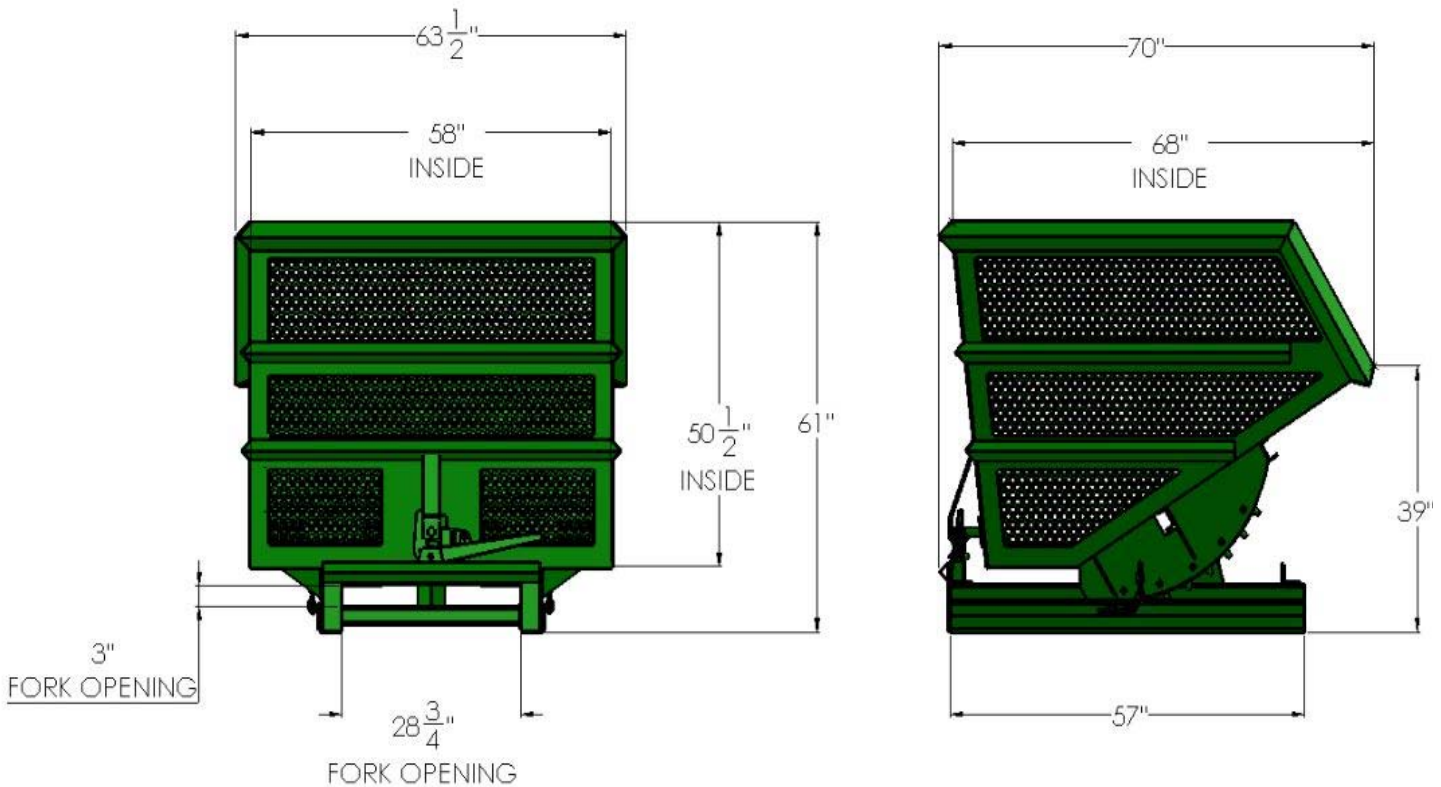
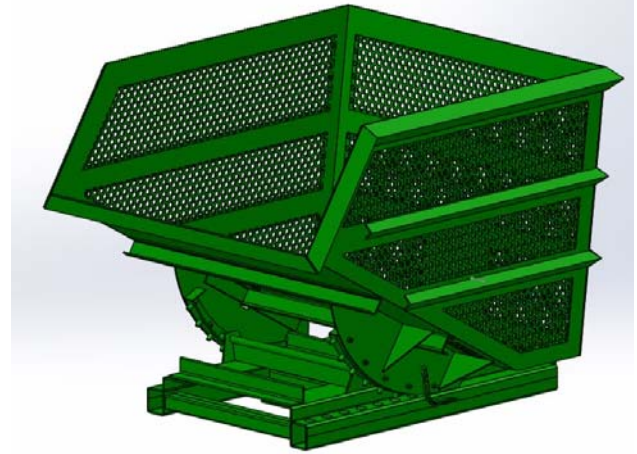

- **COMMON APPLICATIONS:** PULP, AGGREGATE, WASTE AND ANY WET MATERIAL COLLECTION APPLICATIONS.
- 1/4" PLATE STEEL BODY WITH PERFORATION PATTERN OF Ø 1/2" HOLES ON 11/16" STAGGERED CENTERS NET 48% OPEN AREA.
- 6,000 LBS. MAX LOAD CAPACITY.
- BRIGHT SAFETY GREEN ENAMEL PAINT (OPTIONAL COLORS AVAILABLE).
- CUSTOM SIZES ARE AVAILABLE UPON REQUEST.

"FOR ALL YOUR MATERIAL HANDLING NEEDS!"