

RTB-ULT-135 (ULTIMATE ROTATOR BOX) 6500 LBS

MODEL #	L	W	H	WEIGHT
RTB-ULT-135	39"	38 1/2"	27"	360 LBS

1/2 YARD VOLUME CAPACITY

The Ultimate Rotator Box is designed for the collection and storage of bulk and scrap material. This box can be dumped using a forklift equipped with a rotational fork attachment. The standard model is made of all welded carbon steel with drain plug and 2-way fork entry.

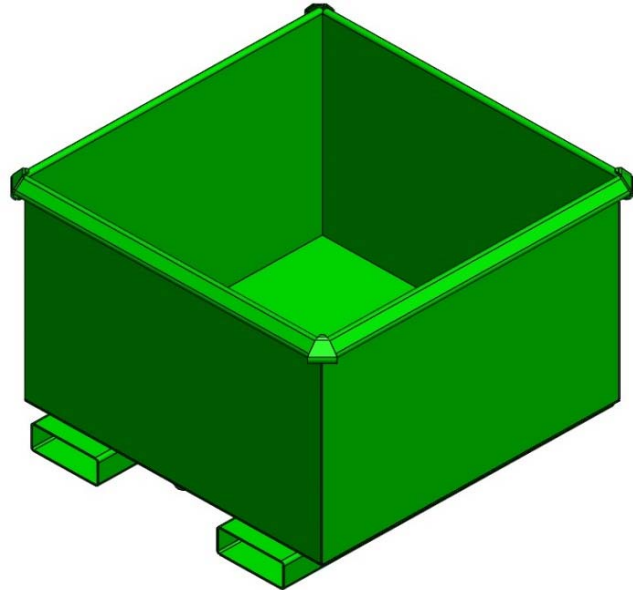

ROURA
MATERIAL HANDLING

Michigan: (800) 968-9070

Mississippi: (800) 654-9147

rourahm.com



**Made In
the U.S.A.**

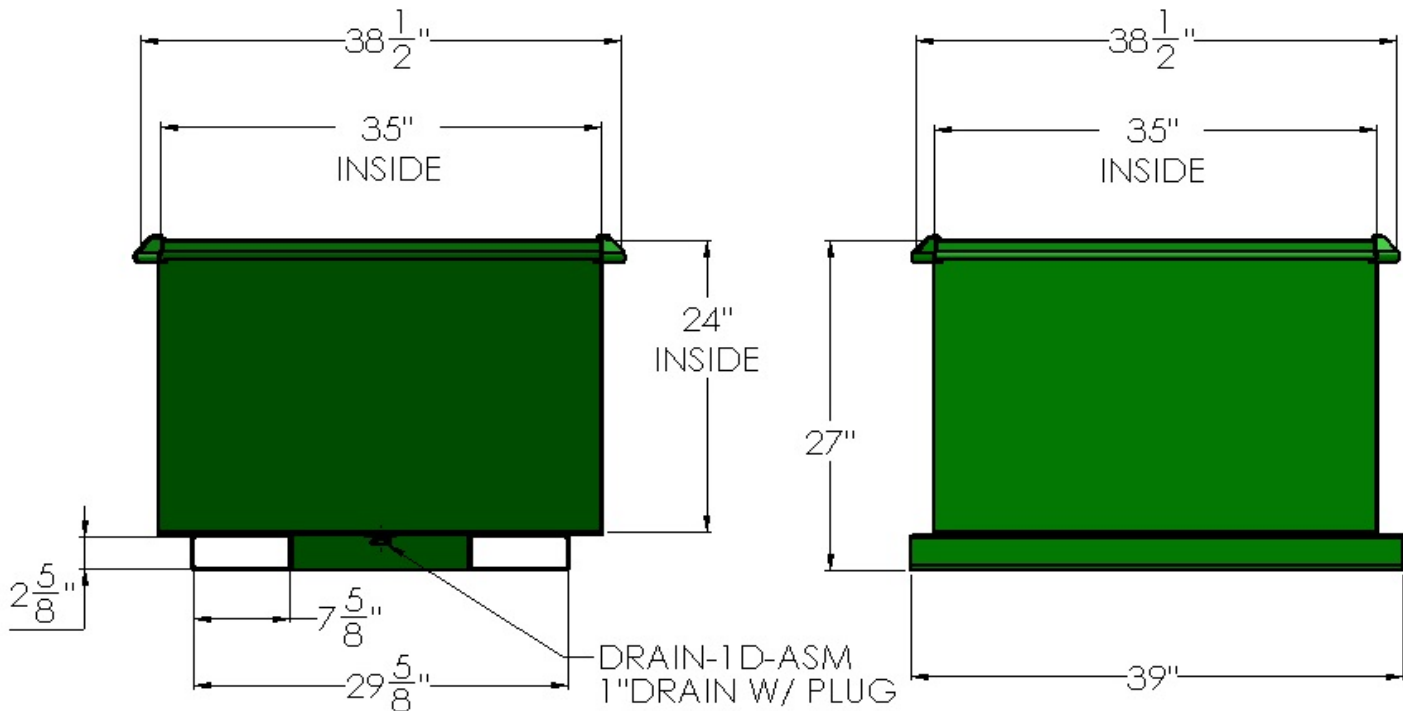

- 7 GAUGE STEEL BOTTOM WITH DRAIN AND PLUG, 7 GAUGE STEEL FORMED SIDES. BOX TUBE FORK OPENINGS FOR SUPERIOR STRENGTH WITH SKID PLATES.
- 6500 LBS. MAX LOAD CAPACITY.
- BRIGHT SAFETY GREEN ENAMEL PAINT (OPTIONAL COLORS AVAILABLE).
- STACKABLE (3 EMPTY BOXES HIGH RECOMMENDED).
- OPTIONS: STEEL HINGED COVER, 4-WAY ENTRY, CASTERS, CRANE EYES, TARPS.
- CUSTOM SIZES ARE AVAILABLE UPON REQUEST.

"FOR ALL YOUR MATERIAL HANDLING NEEDS!"