



ROURA
MATERIAL HANDLING

Michigan: (800) 968-9070

Mississippi: (800) 654-9147

rouramh.com

REFUSE HOPPER MODEL

RRH-72 2 CU YD



MODEL #	SIZE	L	W	H	WEIGHT	CAPACITY
RRH 72	2 CU YD	60"	72"	61"	825 LBS	2000 LBS

REFUSE HOPPER RRH-72

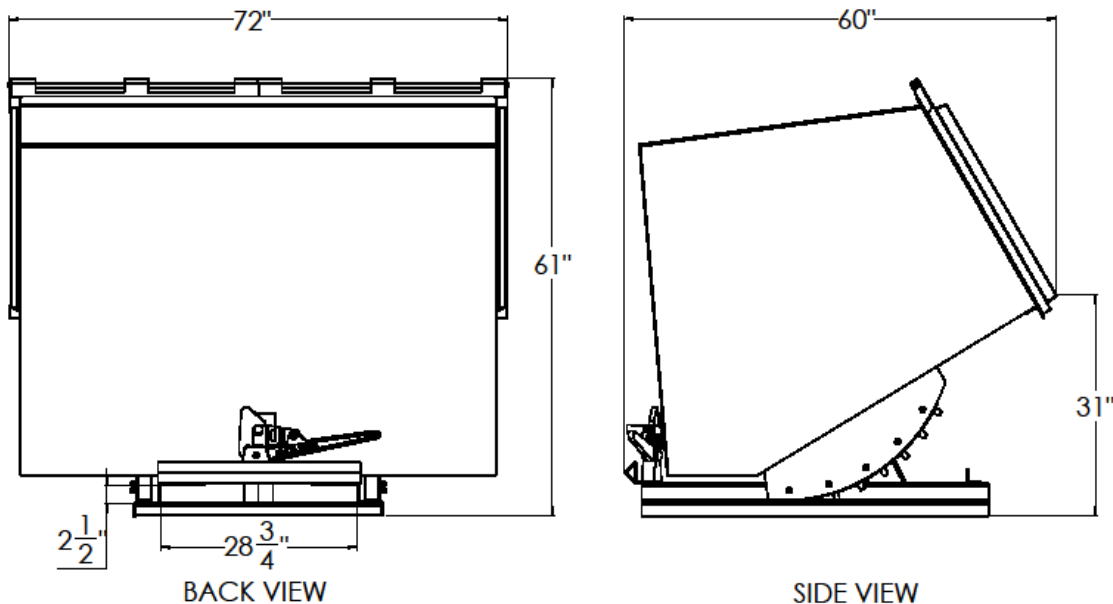

CONSTRUCTION: 3/16" formed plate base. 12 gauge top, bottom and sides with a 36" plastic lid. Ductile iron handle, standard stops, and secure flip latch are standard on this model.

FINISH: Bright safety green enamel paint (other colors optional).

OPTIONAL ITEMS ARE AVAILABLE

"FOR ALL YOUR MATERIAL HANDLING NEEDS!"