



ROURA
MATERIAL HANDLING

Michigan: (800) 968-9070

Mississippi: (800) 654-9147

rouoramh.com



**Made In
the U.S.A.**

RRB-10-205 (RUGGED ROTATOR BOX)

MODEL #	L	W	H	WEIGHT
RRB-10-205	37"	37 1/2"	33 3/8"	263 LBS

The Rugged Rotator Box is designed for the collection and storage of bulk and scrap material. This box can be dumped using a forklift equipped with a rotational fork attachment. The standard model is made of all welded carbon steel with drain plug and 2-way fork entry.

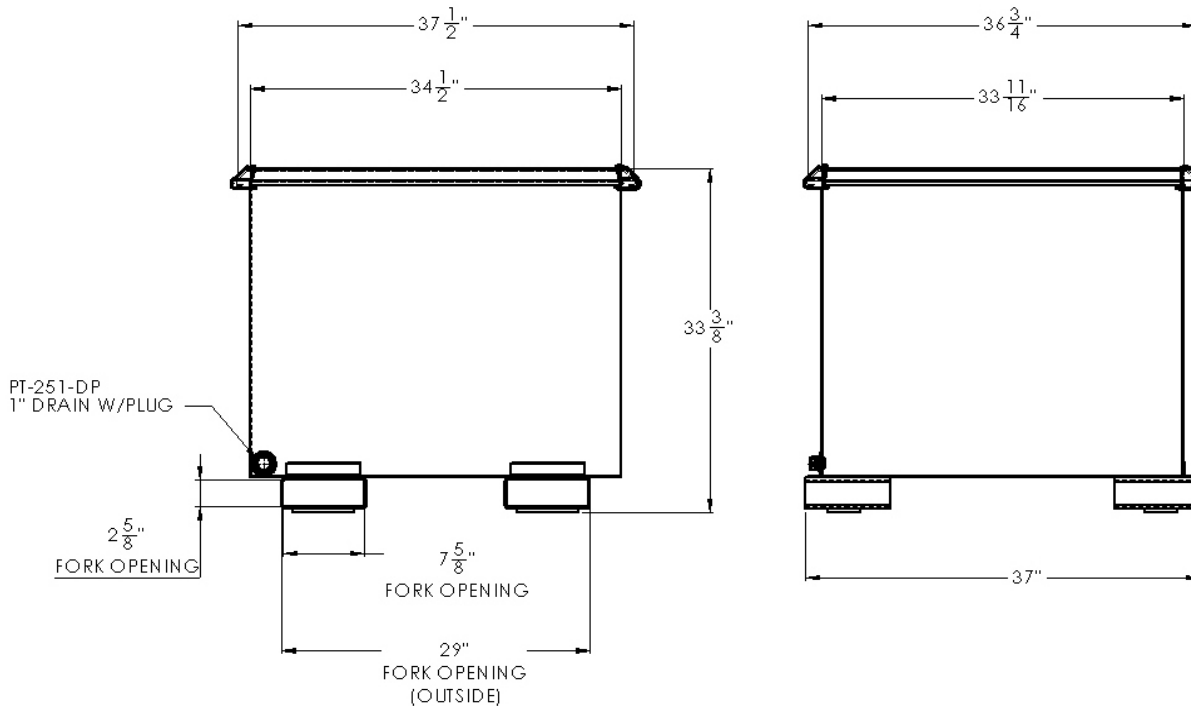
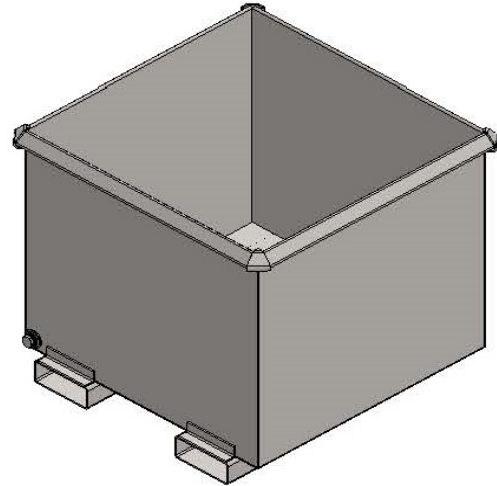

- **10 GAUGE STEEL BOTTOM, 10 GAUGE STEEL FORMED SIDES. STRUCTURAL BOX TUBE FORK OPENINGS FOR SUPERIOR STRENGTH WITH SKID RESISTANCE PLATES.**
- **4000 LBS. MAX LOAD CAPACITY.**
- **BRIGHT SAFETY GREEN ENAMEL PAINT.**
- **STACKABLE (3 EMPTY BOXES HIGH RECOMMENDED).**
- **OPTIONS:** PLASTIC LID, CASTERS, 4-WAY ENTRY BASE, CRANE EYES, TARPS, CUSTOM COLORS.
- **CUSTOM SIZES ARE AVAILABLE UPON REQUEST.**

"FOR ALL YOUR MATERIAL HANDLING NEEDS!"