

DURABLE 1/4 CU YD 90° HOPPER 1,000 LBS

MODEL #	L	W	H	WEIGHT
D90-068	45 3/4"	52 1/8"	15 1/4"	335 LBS

1/4 YARD VOLUME CAPACITY

This hopper dumps to a full 90 degrees when attached to a forklift truck. It is designed for the collection of scrap, waste and recycled material used from CNC machining centers and conveyors. The hopper returns to an upright position when lowered to the ground.

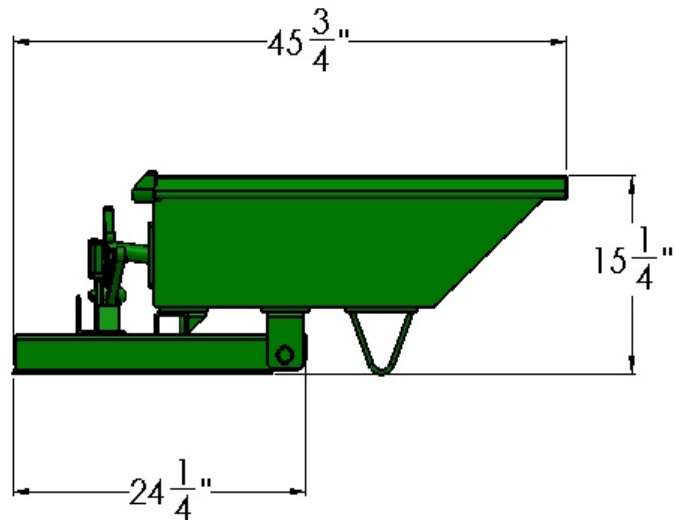
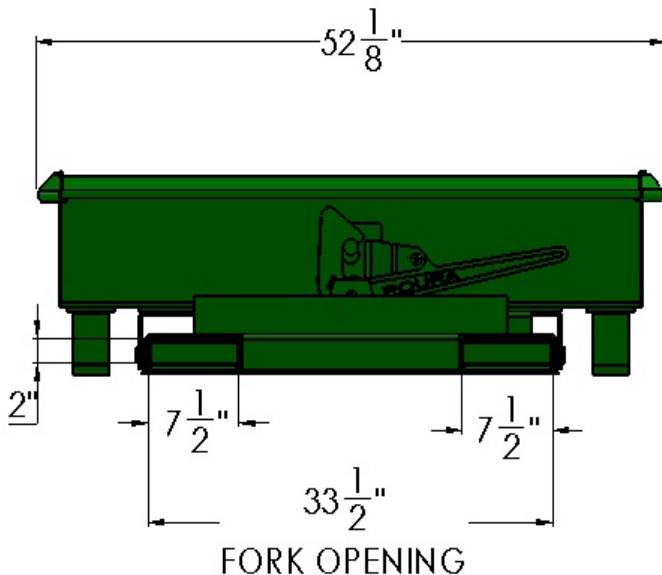
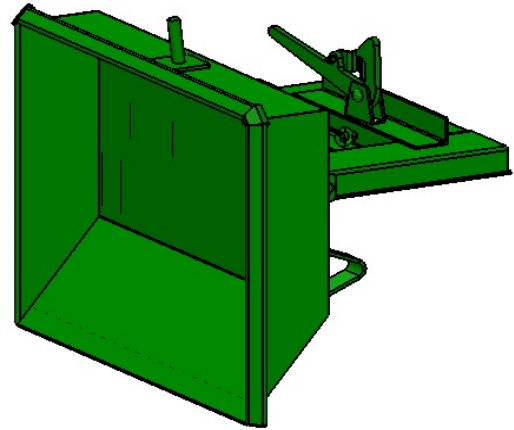

- **COMMON APPLICATION:** CNC MACHINING CENTERS, CONVEYORS AND SMALL SPACES.
- **10 GAUGE STEEL BODY FOR SUPERIOR STRENGTH. THE BASE IS CONSTRUCTED WITH 1/4" HOT ROLLED STEEL.**
- **1,000 LBS. MAX LOAD CAPACITY.**
- **BRIGHT SAFETY GREEN ENAMEL PAINT (OPTIONAL COLORS AVAILABLE).**
- **MAST SECURE CHAIN WITH GRAB HOOK IS INCLUDED.**
- **OPTIONS:** STEEL HINGED COVER, STEEL REMOVABLE COVER, CASTERS, CRANE EYES, TARPS.

"FOR ALL YOUR MATERIAL HANDLING NEEDS!"