



**ROURA**  
MATERIAL HANDLING

Michigan: (800) 968-9070

Mississippi: (800) 654-9147

rouramh.com

## RUGGED HOPPER MODEL

4T-3/16-810 3 CU YD

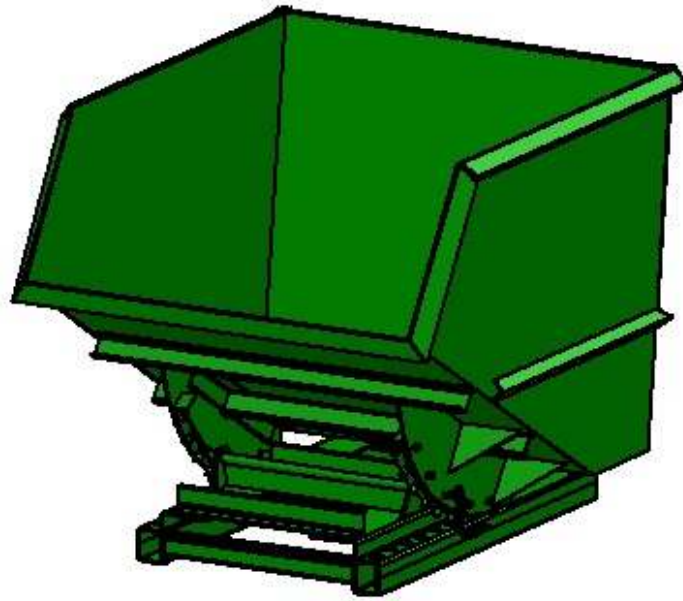

MODEL #	SIZE	L	W	H	LH	FORK OPENING	WEIGHT	CAPACITY
4T-3/16-810	3 CU YD	71"	63 1/2"	61"	39 1/2"	3" X 28 3/4"	1215 LBS	8000 LBS

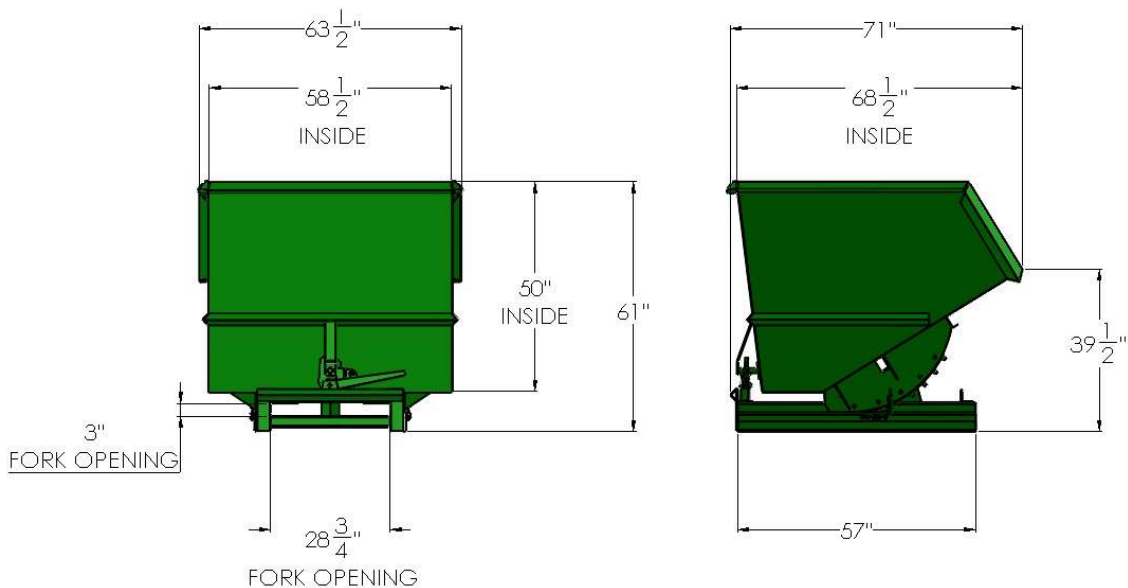

**CONSTRUCTION:** 7 gauge plate body and 5/16" formed box tube base. Bodies are 100% continuous weld for superior construction. Steel handle, continuous stops and secure flip latch are standard on this model.

**FINISH:** Bright safety green enamel paint (other colors optional).

**OPTIONAL ITEMS ARE AVAILABLE**