



ROURA
MATERIAL HANDLING

Michigan: (800) 968-9070

Mississippi: (800) 654-9147

rouramh.com

RUGGED HOPPER MODEL

4T-3/16-1080 4 CU YD

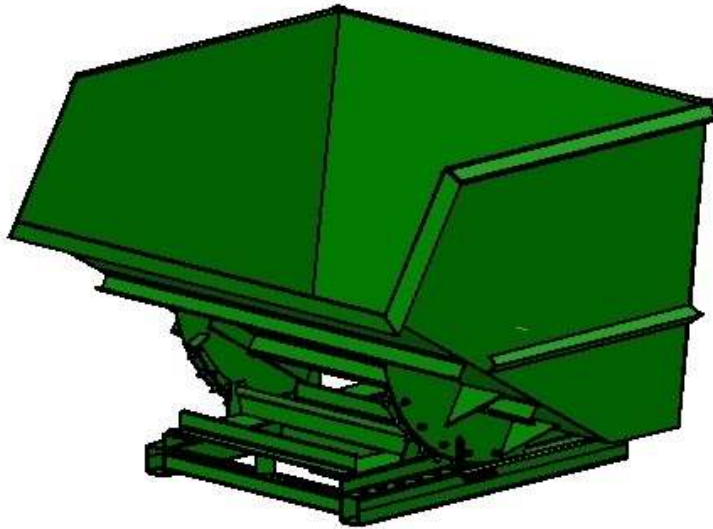

MODEL #	SIZE	L	W	H	LH	FORK OPENING	WEIGHT	CAPACITY
4T-3/16-1080	4 CU YD	71"	83 1/2"	61"	39 1/2"	3" X 37 1/2"	1412 LBS	8000 LBS

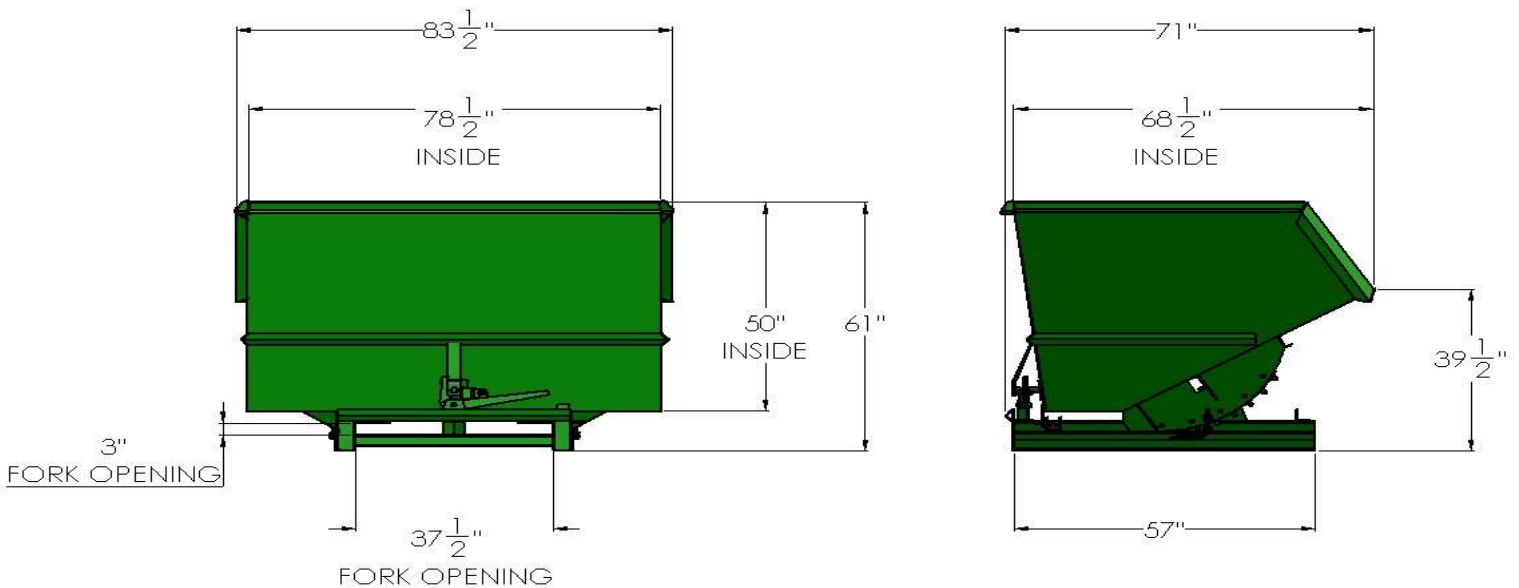

CONSTRUCTION: 7 gauge plate body and 5/16" formed box tube base. Bodies are 100% continuous weld for superior construction. Steel handle, continuous stops and secure flip latch are standard on this model.

FINISH: Bright safety green enamel paint (other colors optional).