



**ROURA**  
MATERIAL HANDLING

Michigan: (800) 968-9070

Mississippi: (800) 654-9147

[rouramh.com](http://rouramh.com)

## ULTIMATE HOPPER MODEL

4T-1/4-680 2-1/2 CU YD



MODEL#	VOLUME	L	W	H	WEIGHT	FORK OPENING	MAX LOAD CAP
4T-1/4-680	2-1/2 Yd <sup>3</sup>	71"	57-1/2"	60"	1320 LBS	2-1/2" X 28-3/4"	8000 LBS

ULTIMATE 4T-1/4-680

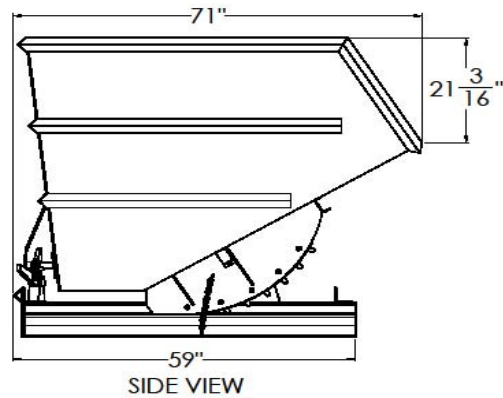
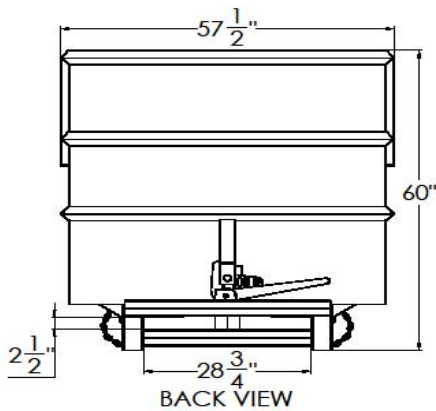

**CONSTRUCTION:** 1/4" plate body, reinforced with 2 additional rows of reinforcing angle, standard 5/16" formed plate base, ductile iron handle with secure flip latch, base to body chains, and heavy duty stops.

**FINISH:** Bright safety green enamel paint.

OPTIONAL ITEMS ARE AVAILABLE

"FOR ALL YOUR MATERIAL HANDLING NEEDS!"