



**ROURA**  
MATERIAL HANDLING

Michigan: (800) 968-9070

Mississippi: (800) 654-9147

rouramh.com

## RUGGED HOPPER MODEL

3T-3/16-270 1 CU YD



MODEL #	SIZE	L	W	H	LH	FORK OPENING	WEIGHT	CAPACITY
3T-3/16-270	1 CU YD	65"	39 1/2"	37 1/2"	35"	2 1/2" X 28 3/4"	583 LBS	6000 LBS

### RUGGED 3T-3/16-270

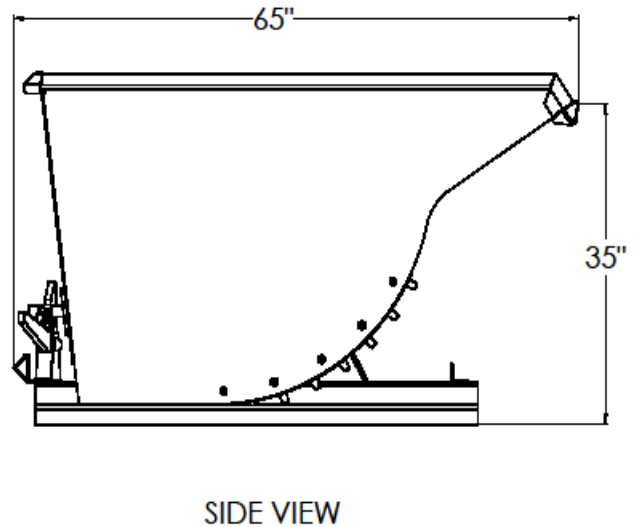
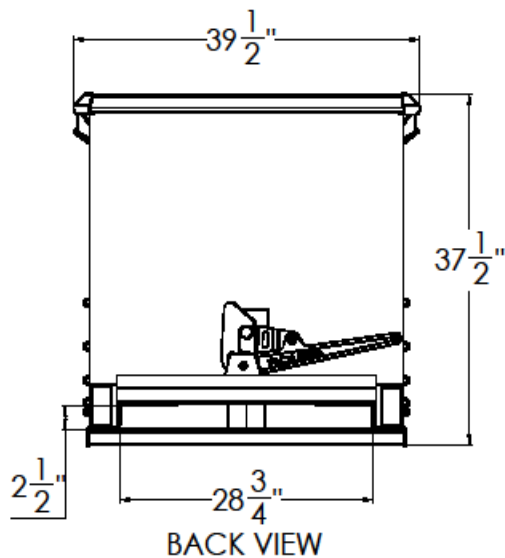

**CONSTRUCTION:** 7 gauge plate body and 3/16" formed plate base. Bodies are 100% continuous weld for superior construction. Ductile iron handle, standard stops and secure flip latch are standard on this model.

**FINISH:** Bright safety green enamel paint (other colors optional).

OPTIONAL ITEMS ARE AVAILABLE

"FOR ALL YOUR MATERIAL HANDLING NEEDS!"