



ROURA
MATERIAL HANDLING

Michigan: (800) 968-9070

Mississippi: (800) 654-9147

rouramh.com

RUGGED HOPPER MODEL

2T-3/16-034 1/8 CU YD



MODEL #	SIZE	L	W	H	LH	FORK OPENING	WEIGHT	CAPACITY
2T-3/16-034	1/8 CU YD	36"	39"	17 1/2"	17 1/2"	2 1/2" X 28 3/4"	242 LBS	4000 LBS

RUGGED 2T-3/16-034

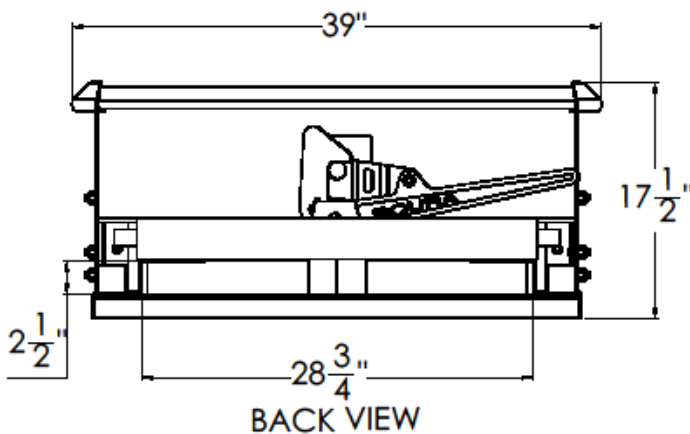

BACK VIEW

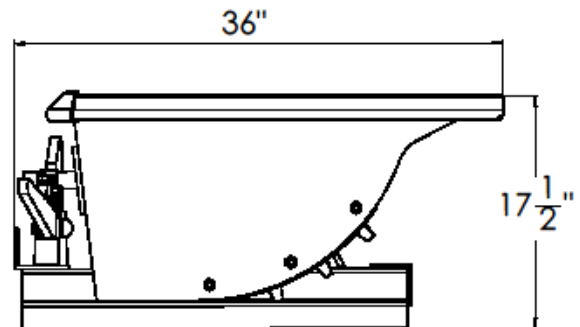

SIDE VIEW

CONSTRUCTION: 7 gauge plate body and 3/16" formed plate base. Bodies are 100% continuous weld for superior construction. Ductile iron handle, standard stops and secure flip latch are standard on this model.

FINISH: Bright safety green enamel paint (other colors optional).

OPTIONAL ITEMS ARE AVAILABLE

"FOR ALL YOUR MATERIAL HANDLING NEEDS!"