



ROURA
MATERIAL HANDLING

Michigan: (800) 968-9070

Mississippi: (800) 654-9147

rouramh.com

DURABLE HOPPER MODEL

2T-10-680 2 ½ CU YD



MODEL #	SIZE	L	W	H	LH	FORK OPENING	WEIGHT	CAPACITY
2T-10-680	2 ½ CU YD	71"	58 ½"	58"	37"	2 ½" X 28 ¾"	843 LBS	4000 LBS

DURABLE 2T-10-680

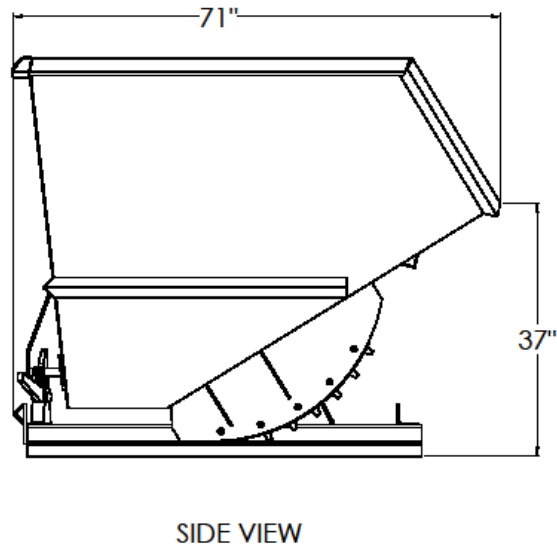
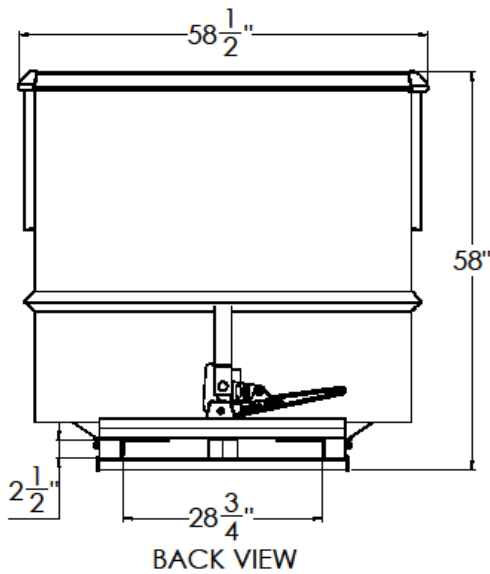

CONSTRUCTION: 10 gauge plate body and 5/16" formed plated base. Bodies are 100% continuous weld for superior construction. Ductile iron handle, standard stops and secure flip latch are standard on this model.

FINISH: Bright safety green enamel paint (other colors optional).

OPTIONAL ITEMS ARE AVAILABLE

"FOR ALL YOUR MATERIAL HANDLING NEEDS!"