



**ROURA**  
MATERIAL HANDLING

Michigan: (800) 968-9070

Mississippi: (800) 654-9147

rouramh.com

## DURABLE HOPPER MODEL

1T-12-105 1/3 CU YD



MODEL #	SIZE	L	W	H	LH	FORK OPENING	WEIGHT	CAPACITY
1T-12-105	1/3 CU YD	49 1/2"	31"	31 1/2"	28 1/2"	2 1/2" X 21"	264 LBS	2000 LBS

### DURABLE 1T-12-105

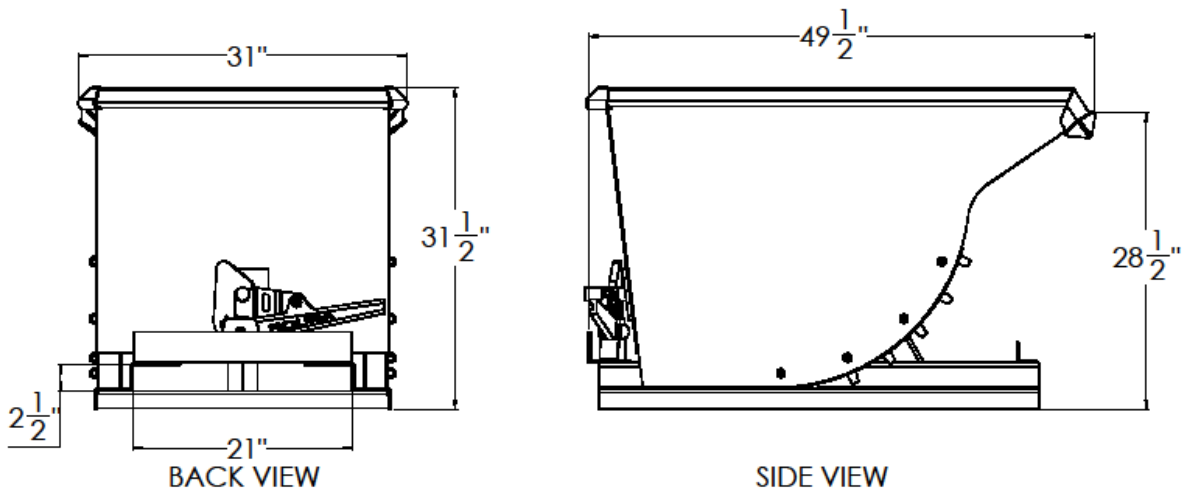

**CONSTRUCTION:** 12 gauge plate body and 3/16" formed plated base. Bodies are 100% continuous weld for superior construction. Ductile iron handle, standard stops and secure flip latch are standard on this model.

**FINISH:** Bright safety green enamel paint (other colors optional).

OPTIONAL ITEMS ARE AVAILABLE

"FOR ALL YOUR MATERIAL HANDLING NEEDS!"