

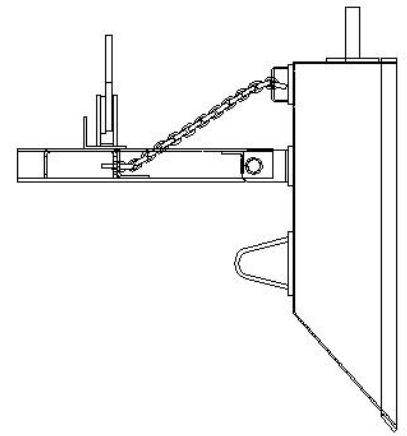

ROURA 90° SELF-DUMPING HOPPER



OPERATING INSTRUCTIONS

SETTING UP THE 90 DEGREE DUMP HOPPER FOR DUMPING

1. With the Lift Truck Forks fully engaged into the hopper fork pocket tubes the operator will prepare the hopper for dumping.
 - a. Unhook the CHAIN-40-MSC-SM Base-To-Mast Chain from the hopper body.
 - b. Wrap the chain around the Mast or Front Carriage and secure it using the clevis hook.
 - c. With the hopper secured to the lift truck mast, you are now ready to transport the hopper to its destination

Always transport the hopper in a safe position 2 to 4 inches from ground level with the mast fully tilted back.

DUMPING THE HOPPER

2. To dump the hopper raise the hopper to a safe dumping position, move the hopper into place, and slowly lower the hopper base onto the top of the container, set the parking brake, and place the lift truck in neutral.
3. With the hopper in a safe position to release the load,
 - a. Push up on the trip lever handle to disengage the handle.
 - For hoppers with a Pull Down Trip Lever, pull the cable handle
 - For Hoppers with a MHR System, Lock and then Pull the retractable handle.

WARNING: Never place hands or arms between hopper body or stop chain. Never stand underneath hopper while dumping.

PLACING THE HOPPER BODY BACK TO THE FILL POSITION

4. To upright the hopper body to the fill position, lower the front nose of the hopper body to the floor. Once the body of the hopper contacts the floor, the hopper body should begin to fall back to the fill position. At this time place the lift truck in reverse and while lowering the forks back the lift truck up a few feet. The hopper body should flip back and lock into the trip lever handle.

The operator should always make sure the area behind them is clear of pedestrians or obstacles before placing the lift truck in reverse and moving backward.

RETURNING THE HOPPER TO BE FILLED

5. Transport the hopper to its destination to be filled, put the hopper in place set the parking brake, place the lift truck in neutral and shut down the fork lift truck.
 - a. If the Hopper is equipped with an MHR System, remove the retractable pull handle from the fork lift trucks overhead guard frame. Using the magnet on the retractable pull handle, safely position it back onto the hopper
 - b. If the hopper is equipped with a pull down handle place the cable & handle back to the cable hook mounted to the hopper.
 - c. Unhook the Base to Mast chain from the lift truck, and place it back on the chain hook located on the hopper body.
6. The Fork Lift Truck can now be fully disengaged from the self-dumping hopper. The hopper is now ready to be filled for another dump cycle.