

# Roura Material Handling, Inc.

Clinton Twp. MI 48035    Holly Springs, MS 38635  
(800) 968-9070    (800) 654-9147  
www.RouraMH.com

## CASTER INSTALLATION & REPLACEMENT INSTRUCTIONS

*Review the entire instruction before assembling the casters onto the hopper. Consult with the factory in the event that there are questions or problems at the time of assembly.*

### CASTER OPTION

NOTE: Hoppers ordered with casters include (4) caster pads (welded in place), (2) swivel casters, and (2) fixed casters.

NOTE: Adding casters will reduce the rolling load capacity of some models. Capacities are: Semi-Steel—1,200 lb. / wheel; Mold-on-Rubber— 600 lb. / wheel; and poly-on-steel—1,200 lb./ wheel.

\*\* Assembly must be performed by a suitably trained personnel with access to the appropriate equipment and tools\*\*

1. Flip the hopper upside down so that the bottom of the hopper frame is facing up. To do this follow the TO FLIP UPSIDE DOWN instructions on the attached sheet,
2. Once the hopper is upside down, locate the caster pad brackets found in both the front and back corners of the hopper frame.
3. The swivel casters are to be placed in the back of the hopper frame and the fixed casters are to be placed in the front of the hopper frame.
4. Place one end of the caster plate into the slot as shown. Set the caster plate down into the caster pad. Replace the bolt and nut which will hold the caster into the caster pad. Repeat these steps on all remaining casters.
5. Return the hopper into the upright position by following the TO FLIP UPRIGHT instructions on the attached sheet.

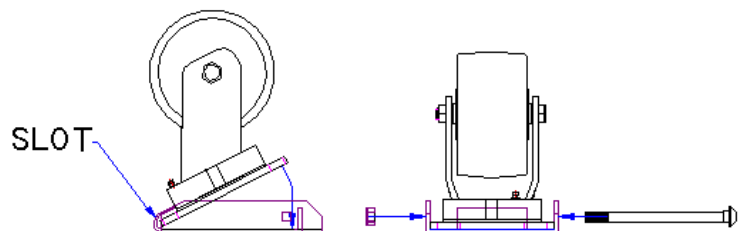
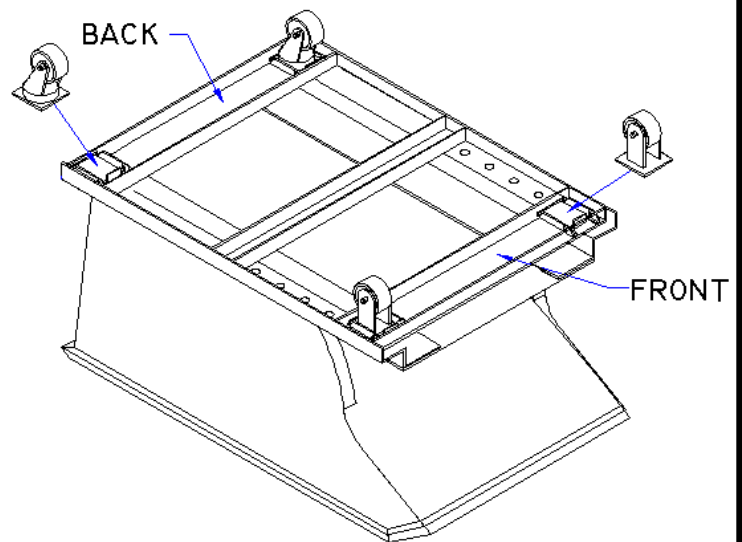

### PARTS

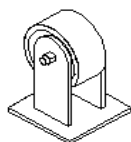

FIXED CASTER

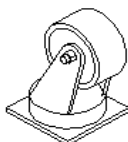

SWIVEL CASTER

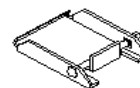

QUICK CHANGE  
CASTER PAD